

16 Ø STAINLESS STEEL CINCH ANCHOR WITH NUT & WASHER  
500mm LONG PASSING  
SSTL LINK CHAIN, 5 Ø  
WITH GRAB HOOK - 2 REQ'D

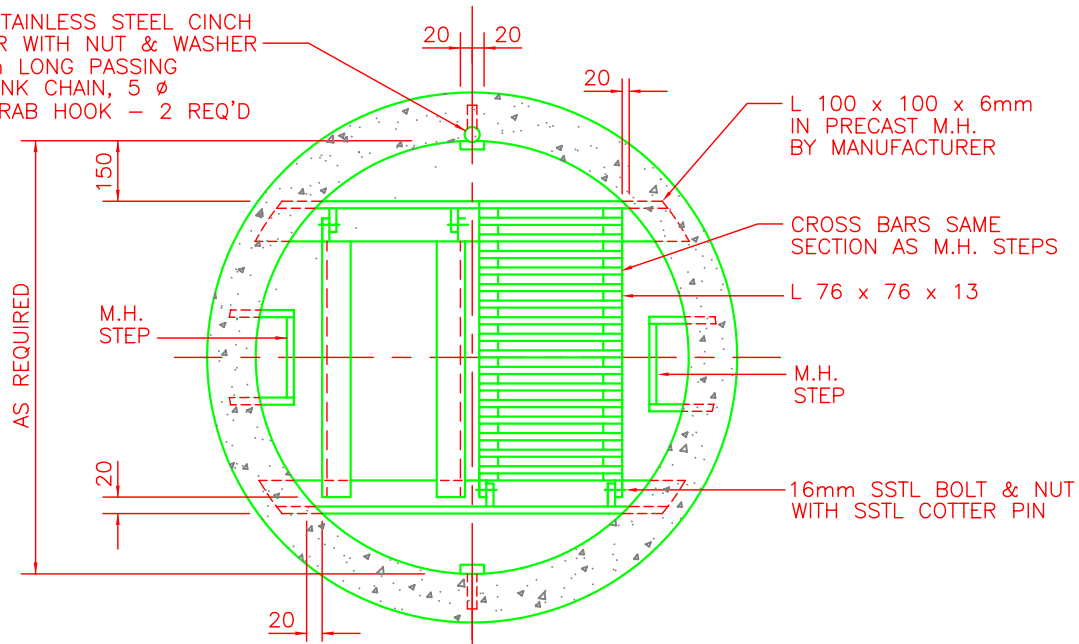

PLAN

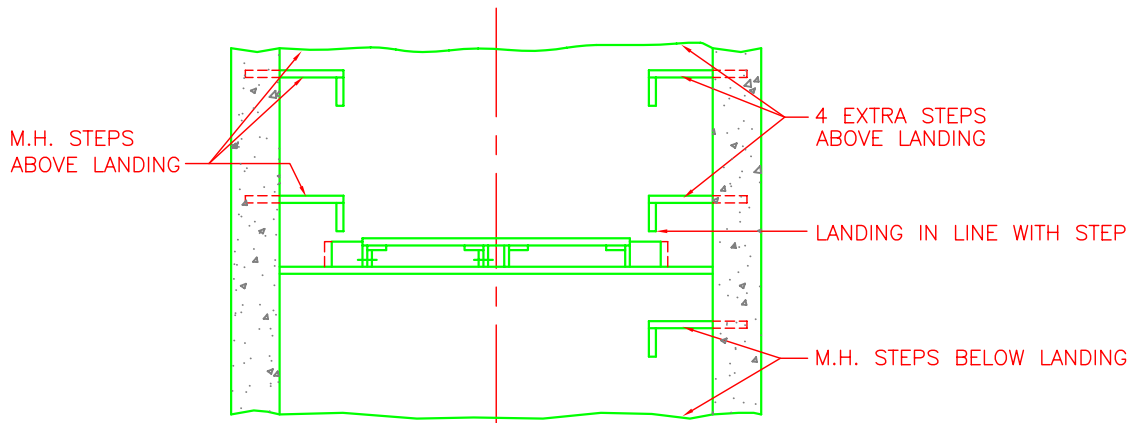

SECTION

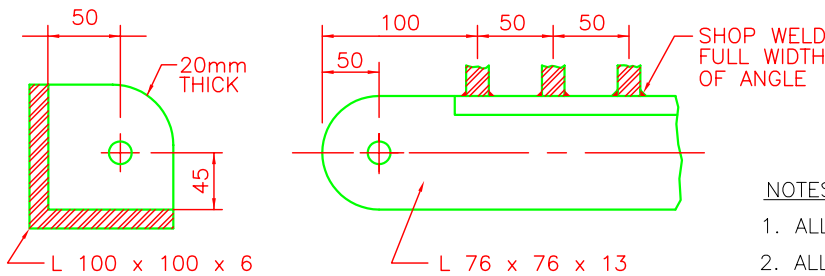

PIVOT DETAIL

NOTES:

1. ALL MATERIAL SHALL BE ALUM ALLOY 6061-T6.
2. ALL BOLTS, NUTS, WASHERS, AND PINS SHALL BE SSTL TYPE 304.
3. ONE COAT OF BITUMINOUS PAINT SHALL BE APPLIED TO ALL ALUM SECTIONS IN CONTACT WITH CONCRETE.
4. PLATFORM TO CONFORM WITH WORKER'S COMPENSATION BOARD REGULATIONS.

UNITS ARE IN MILLIMETERS  
UNLESS OTHERWISE NOTED

**LANDING FOR  
DEEP MANHOLES**  
AS REQUIRED BY W.C.B.  
REGULATIONS

2	City	Drawings revised	02/99
1	Usi	Original drawings created	04/96
No.	By	Revisions	Date

Date: February 12/99	Scale: N.T.S	Dwg. No. F-6
Drawn by: Bob Smith	Cad file: c:\...\drawings\standard\By_F6	